

**Cub™ GENERAL PEDIATRIC CARE STRETCHER
Model FL19**



Technical Assistance and Parts

1 800 428-5025 (Service in English - Canada)

1 800 361-2040 (Service in French - Canada)

1 800 327-0770 (In the United States)

E-mail (Service in Canada): service@bertec.strykercorp.com

Manufactured by Stryker Bertec Medical Inc
F15-44-E-A

July 2002
72-0380 R1.2
Printed in Canada

TABLE OF CONTENTS

1. INTRODUCTION.....	5
1.1 Specifications	5
1.2 Technical Support.....	5
1.3 Warning / Caution / Note Definition.....	6
1.4 Safety Precautions	6
1.5 Warranty.....	8
Limited Warranty	8
To Obtain Service and/or Replacement Parts.....	8
Return Authorization.....	9
Damaged Merchandise	9
2. CLEANING AND PREVENTATIVE MAINTENANCE.....	10
2.1 Stretcher Cleaning and Mattress Care	10
Cleaning Stretcher.....	10
Mattress Care.....	10
2.2 Preventative Maintenance Program.....	11
Biannual Checklist.....	11
Base Lubrication.....	12
Recommended Spare Parts	13
3. MAINTENANCE	14
3.1 Hydraulic Jack Replacement / Litter Removal.....	14
3.2 Checking Hydraulic Fluid Level.....	16
3.3 Constant Flow Jack Descent Rate Adjustment	17
3.4 Removing Excess Air from the Hydraulic System	17
3.5 Hydraulic Valve Replacement.....	18
Poppet Valve.....	18
Check Valve	18
3.6 Adjustable Pressure Compensated (P.C.) Valve Replacement.....	19
3.7 Fifth Steer Wheel Component Replacement.....	20
Litter Assembly Removal - Fixed Height Stretcher.....	20
Wheel Arm Assembly	21
Fifth Wheel Caster.....	22
Neutral Guide Plate	23
Brake/Steer Pedal	23
3.8 Brake Bar Replacement - Hydraulic Stretcher	24
3.9 Brake Adjustment - Hydraulic Stretcher	25
3.10 Caster Assembly Replacement.....	25
3.11 Hydraulic Base Pedal Replacement.....	26
Pump Pedal.....	27
Uni-Lower Pedal.....	27

3.12 Pneumatic Assist Fowler Component Replacement	28
Head Section	28
Pneumatic Cylinder	29
Fowler Assist Cable	29
Fowler Activation Lever.....	30
3.13 Manual Fowler Component Replacement	30
Head Section	30
Head Support Arm	30
3.14 Side/End Rail Component Replacement	31
Handle Assembly	31
Central Column Assembly.....	32
Rail Upper/Lower Cover.....	34
Rail Support Rolling Bearing	35
Rail Assist Cable	36
3.15 Access Door Component Replacement.....	38
Hinge and Latch Mechanisms Component.....	38
Release Knob	39
Upper/Lower Plastic Cover.....	40
Access Door Removal.....	40
ANNEX A: Installation Procedure for a Fixed Endrail	41

1. INTRODUCTION

This manual is designed to assist you with the servicing of the Model FL19 Cub Pediatric Stretcher. It is extremely important for the patient's safety to read and understand all information in this manual before servicing the stretcher. Qualified service personnel should be able to refer to this manual at all time.

This Maintenance Manual is an integral part of the stretcher and should be included if the unit is sold or transferred.

1.1 SPECIFICATIONS *

Maximum Weight Capacity	400 lb (181 kg)
Maximum Lifting Capacity (Hydraulic Model)	100 lb (45 kg)
Overall Length/Width - w/o Premium Accessory Brackets - w/Premium Accessory Brackets	65 1/4" x 37 1/8" (166 cm x 94 cm) 72 3/8" x 37 1/2" (184 cm x 95 cm)
Overall Weight - Hydraulic Model - Fixed Height Model	365 lb (166 kg) 300 lb (136 kg)
Fowler Articulation Angle - Manual Activated - Pneumatic Assist	0°, 25°, 40°, 55° 0° to 50°
Height Range (to litter top) - Low - High	Hydraulic: 32" (81 cm); Fixed Ht: 32" (81 cm) Hydraulic: 40" (102 cm); Fixed Ht: 32" (81 cm)
Foot Section Angle	0°, 6°, 12°
Brake System - Hydraulic Stretcher - Fixed Height Stretcher	Four Wheel Ring Brake System Four Locking Casters

* Stryker Bertec provides special attention to product improvement and reserves the right to change specifications without notice.

1.2 TECHNICAL SUPPORT

For questions regarding this product, contact the following Technical Service department or your local representative:

In Canada:

Stryker Bertec Medical Inc
Service in English: 1 800 428-5025
Service in French: 1 800 361-2040
E-mail (in Canada): service@bertec.strykercorp.com
70, 5th Avenue, P.O. Box 128
L'Islet (Quebec), G0R 2C0, Canada

In the United States:

Stryker Medical Inc
1 800 327-0770
6300 South Sprinkle Road
Kalamazoo, MI 49001-9799
USA

1.3 WARNING / CAUTION / NOTE DEFINITION

The words **WARNING**, **CAUTION** and **NOTE** carry special meanings and should be carefully reviewed.



WARNING

The personal safety of the patient or user may be involved. Disregarding this information could result in injury to the patient or user.



CAUTION

These instructions point out special procedures or precautions that must be followed to avoid damaging the equipment.

NOTE

Notes provide special information to make maintenance easier or important instruction clearer.

1.4 SAFETY PRECAUTIONS

The following is a list of safety precautions that must be observed when operating or servicing the Cub Pediatric Stretcher. They are repeated throughout the manual, where applicable. For the patient's safety, carefully read and strictly follow them before operating or servicing this unit.



WARNING

- Staff and personnel should ensure a safe environment to the patient by verifying that the stretcher components (rails, access doors, accessories) are in good condition and properly secured before placing a patient on the stretcher.
- Always apply the brakes when a patient is removed from or placed on the stretcher. Always engage the brakes unless the stretcher is being moved. Push on the stretcher to ensure the brakes are securely locked. Injury could result if a stretcher moves while a patient is placed or removed from the stretcher.
- When brakes are applied on a fixed height stretcher, ensure all four casters are locked to ensure complete stabilization of the stretcher.
- To reduce risk of injury, ensure the litter is horizontal and in the lowest position with the rails fully raised when moving the pediatric stretcher with a patient on it.
- The rails must always remain in the highest position and the litter in the lowest position unless a patient is being tended. Never leave a patient unattended when the rails are lowered.
- Make sure that proper policies are put in place to ensure the patient's safety when an IV pole and/or an oxygen bottle are used. The patient should not be able to reach and manipulate them.
- To avoid injury to patient and/or user or damage to the unit, ensure the rails are in their highest position before lowering the litter and verify that all equipment and persons are removed from the area below and around the litter.
- To avoid falls and injury, verify the rails and access doors are properly locked into position before leaving a patient unattended or after having moved a rail or an access door.
- To avoid injury to the patient, ensure the patient's extremities are clear of all moving parts before operating a rail. Always ensure the rail is securely locked after moving it.

- To avoid falls and injury, ensure that the access door open/close indicators (located on both lock release knobs) show green when the door is closed and locked into position. If one or both open/close indicators are yellow, the door is not completely closed and locked.
 - Avoid using an access door or a rail handle as push/pull devices or damage to the unit or injury to the patient and/or user may occur.
 - To avoid injury to the patient and/or user, do not attempt to move the stretcher directly sideways with the fifth wheel engaged. The fifth steer wheel cannot pivot.
 - To avoid injury to the patient, verify the patient is safely positioned on the litter before lowering the siderail and operating the Fowler or foot section.
 - To avoid injury when raising or lowering the manual Fowler or the foot section, verify the support arm is securely engaged in the arm supports before releasing the Fowler or foot section.
 - When patient is able to climb out the stretcher or reaches the height of 35 in. (90 cm), the stretcher shall no longer be used.
 - Do not place cords, straps or similar items that could become wound around the patient's neck in or near the stretcher.
 - Do not leave objects or toys in the stretcher.
 - Do not use a water mattress with this stretcher.
 - To avoid injury to the patient, any mattress used on this stretcher must be at least 57 1/2" (146.05 cm) long by 29 3/8" (74.6 cm) wide and not less than 3" (7.6 cm) or more than 6" (15.3 cm) thick.
 - Failure to properly clean the mattress, or dispose of it if defective, may increase the risk of exposure to pathogenic substances and may cause injury to the patient and/or user.
 - Do not use the stretcher if any components are missing or broken. Contact your dealer or Stryker Bertec for replacement parts. Use only replacement parts provided by Stryker Bertec Medical.
 - Maximum Static Weight Capacity = 400 lb (181.4 kg).
-

NOTE

Throughout the manual, the words "right" and "left" refer to the right and left sides of a patient lying face up on the stretcher.

1.5 WARRANTY

LIMITED WARRANTY

All Stryker Bertec products are guaranteed against material or workmanship defects, improper operation of mechanisms, and premature wear of stretcher components under normal use conditions.

For questions regarding the warranty, please contact our Technical Service department (see section 1.2) or your local representative.

TO OBTAIN SERVICE AND/OR REPLACEMENT PARTS

To Require Service

For an on-site diagnosis of a malfunction by a Stryker Field Service Representative, contact our Technical Service department (see section 1.2) or your local representative.

To Order Replacement Parts

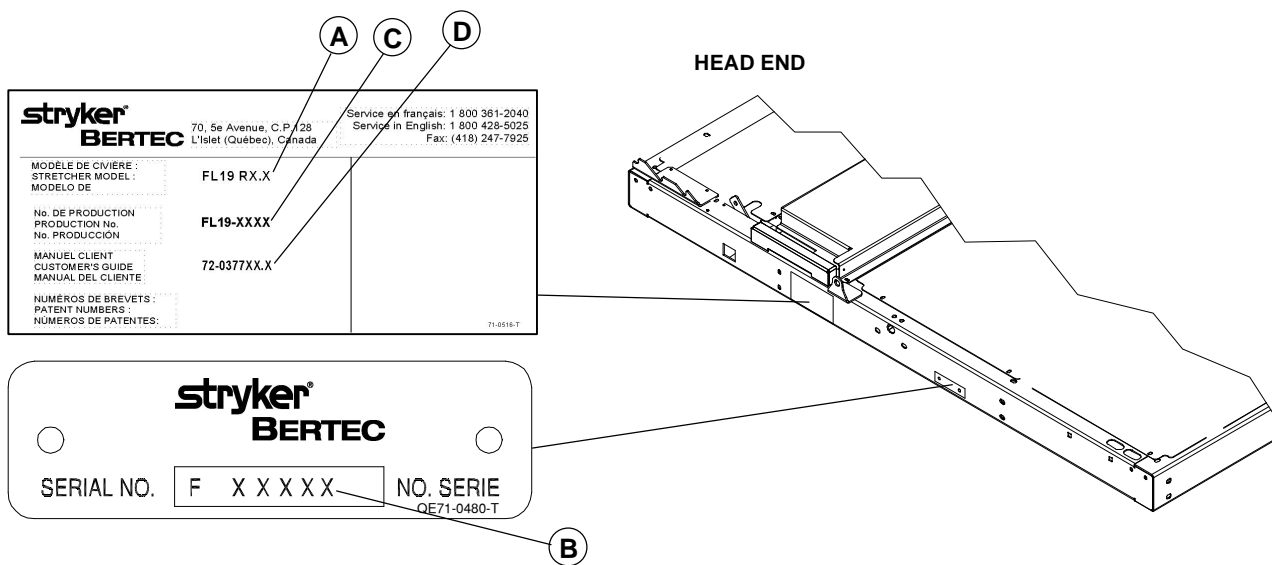

Figure 1.5

To order replacement parts, contact our Technical Service department or your local representative and provide the following information:

- Model number (A)
- Serial number (B)
- Production number (C)
- Name and part number of the defective part, which can be found in the Parts Lists included in the Customer's Guide, whose code number (D) is printed on the manufacturer's nameplate.

NOTE

It is very important that you refer to the Customer's Guide drawings and parts lists that are specific to the stretcher being repaired.

- Description of the problem encountered.

NOTE

We will do our best to help you identify the parts to be replaced. However, if an error occurs when ordering, the user remains responsible for identifying the parts needed. Stryker Bertec Medical will take back wrong parts ordered but will not assume shipping charges, and restocking fees will be charged to the user, unless a Technical Service Representative has been requested for an on-site diagnosis.

RETURN AUTHORIZATION

Merchandise cannot be returned without approval from the Technical Service department. An authorization number will be provided, which must be clearly printed on the returned merchandise. Stryker Bertec reserves the right to charge shipping and restocking fees on returned items.

DAMAGED MERCHANDISE

Claims for damaged merchandise must be made with the carrier within fifteen (15) days of receipt of merchandise. **DO NOT ACCEPT DAMAGED SHIPMENTS UNLESS SUCH DAMAGE IS NOTED ON THE DELIVERY RECEIPT AT THE TIME OF RECEIPT.** Upon prompt notification, Stryker Bertec will file a freight claim with the appropriate carrier for damages incurred. Claims will be limited in amount to the actual replacement cost. In the event that this information is not received by Stryker Bertec within the fifteen (15) days period following the delivery of the merchandise, or the damage was not noted on the delivery notice at the time of receipt, the customer will be responsible for payment of the original invoice in full.

Claims for any short shipment must be made within 5 days of invoice.

2. CLEANING AND PREVENTATIVE MAINTENANCE

2.1 STRETCHER CLEANING AND MATTRESS CARE

CLEANING STRETCHER

Hand wash all surfaces of the stretcher with a soft cloth moistened with a solution of lukewarm water and a mild detergent.

Wipe the stretcher clean and dry thoroughly to avoid build up of cleaning solution.



CAUTION

Do not use harsh cleaners, solvents or detergents. Do not steam clean, hose off or ultrasonically clean the stretcher.

Germicidal disinfectant, used as directed, and/or chlorine bleach products are not considered mild detergents. These products are corrosive in nature and may cause damage to your stretcher if used improperly. If these types of products are used, ensure the stretchers are rinsed with clean water and thoroughly dried following cleaning. Failure to properly rinse and dry the stretchers will leave a corrosive residue on the surface of the stretcher, possibly causing premature corrosion of critical components. Failure to follow the above directions when using these types of cleaners may void this product warranty.

MATTRESS CARE



WARNING

Inspect the mattress after each use. Discontinue use if any cracks or rips are found in the mattress cover which may allow fluid to enter the mattress. Failure to properly clean the mattress, or dispose of it if defective, may increase the risk of exposure to pathogenic substances and may cause injury to the patient and/or user.

- **Inspection**

Implement local policies to address regular care, maintenance, and cleaning of mattresses and covers. The cover cleaning procedure can be found below and on the mattress label.

Inspect mattress cover surface (also zip fasteners and cover inner surface if mattresses have zip fasteners) regularly for signs of damage. If the mattress cover is stained, soiled, or torn, remove the mattress from service.

- **Cleaning**

Stains: Wash with lukewarm water using a mild detergent. Rinse with water and let dry. For tough stains, use chlorine bleach diluted with ten parts of water.

2.2 PREVENTATIVE MAINTENANCE PROGRAM**WARNING**

Only qualified service personnel should perform the procedures detailed in this maintenance manual. Failure to observe this restriction can result in serious damage to material and/or severe injury to people.

The use of greases different than the one recommended (OG2 grease) could lead to deterioration of critical parts and to mechanism failure, resulting in injury to the patient or operator and damage to the stretcher.

When servicing, use only identical replacement parts provided by Stryker Bertec

**CAUTION**

The pediatric stretcher uses oil-impregnated shoulder spacers at hinge points. **Do not** lubricate these shoulder spacers. When shoulder spacers are found worn, they must be replaced.

BIANNUAL CHECKLIST

This preventative maintenance program should be performed at least **twice** a year.

- ___ Side/endrail handle trigger and rotating movement operate properly.
- ___ Side/endrails raise and lower smoothly, and lock in the 9", 14" and upper positions. If a siderail moves with difficulty, remove the brake shoe cover and adjust the position of the stop catches. Refer to step 11 of the "Central Column Assembly" replacement procedure, page 34 of this manual.
- ___ Side/endrails automatically stop at the 9" position when lowered without interruption (handle kept rotated to the left or right while lowering the rail) from upper positions. Rotating the handle to the left or right further lowers the rail from the 9" position to its lowest position under the mattress surface.

NOTE

On some stretchers, the 9" double safety lock may not be present following the optional removal of this safety feature.

- ___ Optional access doors open, close and lock properly. Release knobs operate properly.
- ___ Check the optional access door open/close color indicators for proper operation. Green should appear when the door is closed and locked, and yellow when the door is open. Verify the access doors are closed and locked when both open/close indicators show green.
- ___ Optional pneumatic assist Fowler operates properly.
- ___ Manual Fowler operates properly.
- ___ Foot section support arm operates properly.
- ___ No rips or crack in mattress cover.
- ___ Optional brake pedal operates properly. All casters lock with the brake pedal engaged.
- ___ Optional steer pedal operates properly. Fifth steer wheel operational with the steer pedal engaged.
- ___ Optional lift pedal operates properly. Litter raises when the pedal is pumped.
- ___ Optional uni-lower pedal operates properly. Trendelenburg positions and litter descent are operational when uni-lower pedal is depressed.
- ___ All casters secure and swivel properly.
- ___ Fixed height stretcher four casters lock and unlock properly using the brake lever.
- ___ Ground chain intact.

- ___ No oil leak on optional hydraulic jacks.
- ___ Optional hydraulic jacks holding properly.
- ___ Optional hydraulic jack oil level sufficient.
- ___ Optional retracting protective top secure and working properly.
- ___ Optional IV Caddy secure and working properly.
- ___ Optional accessory brackets secure.
- ___ All plastic covers (including the base hood) intact. Replace if broken. The security of the patient could be at stake if any siderail plastic cover is cracked, as sharp edges may be present.
- ___ All fasteners secure; all welds intact.
- ___ Lubricate where required (see section 2.2, "Base Lubrication" in the Maintenance Manual).

Serial No.: _____

Completed By: _____

Date: _____

BASE LUBRICATION

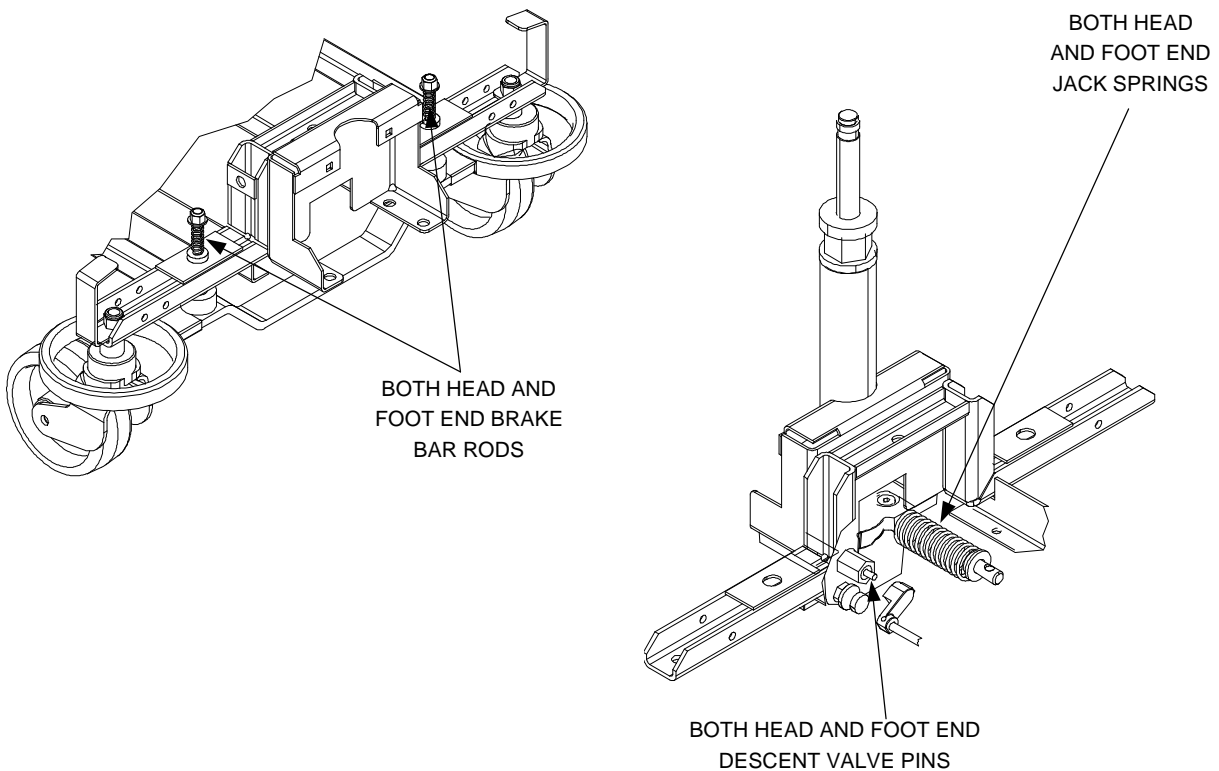

Figure 2.2

RECOMMENDED SPARE PARTS

The following is a list of recommended on hand spare parts for the pediatric stretcher.

Base Assembly Parts	P/N	Parts List No.
Fifth Wheel Caster	RL5	OL190006
5" Lock Caster (Fixed Height Stretcher)	RT5TF	OL190009
6" White Caster (Hydraulic Stretcher)	19-0718	OL190008
Brake Bar	19-0382S	OL190008
Neutral Guide Plate	QR19-0812	OL190008
Hydraulic Raising Pedal	QDF5056	OL190001
Hydraulic Lowering Pedal	QDF5061	OL190001
Butterfly Brake Pedal	QDF5059	OL190008
Base Hood	QP19-0359	OL190001
O ₂ Bottle Retaining Collar (Option)	QDF5071	OL190045
Black Bellow	QDF5053	OL190001
Constant Descent Hydraulic Jack	QDF5060	OL190001
Litter Assembly Parts		
Head Section	19-0052P	OL190024
Foot Section	19-0053P	OL190024
Velcro Mattress Fastener	19-0135	OL190024
Foot Section Support Arm	19-0749	OL190043
Manual Fowler Support Arm	19-0761	OL190025
Pneumatic Assist Fowler Cable	QDF190354	OL190024
Pneumatic Assist Fowler Gas Cylinder 600N	QDF5087	OL190024
Pneumatic Assist Fowler Activation Lever	QP19-0210	OL190024
Rail and Access Door Assembly Parts		
Rolling Bearing Support	19-0305	OL190014
Handle Assembly	See with Tech. Serv.	OL190026
Central Locking Column Assembly	See with Tech. Serv.	OL190026
Rail Assist Cable	19-0381	OL190019
Siderail Upper Cover	QP19-0465-10	OL190010
Endrail Upper Cover	QP19-0466-10	OL190015
Access Door Release Knobs - Outer Part	QP19-0545	OL190016
Access Door Release Knobs - Inner Part	QP19-0546	OL190016
Access Door Hinge - Outer	19-0402Z	OL190016
Access Door Hinge - Inner	19-0403Z	OL190016
Left Access Door Upper Cover	QP19-0553-10	OL190016
Right Access Door Upper Cover	QP19-0637-10	OL190017
Assist Mechanism Cable	19-0381	OL190019-20
Miscellaneous Parts		
Shoulder Spacers	QDF17-0020	
White Touch-Up Spray Paint	HS412W117	
OG2 Grease	M0027	

3. MAINTENANCE

3.1 HYDRAULIC JACK REPLACEMENT / LITTER REMOVAL

Required Tools:

Phillips Screwdriver	Supports (2)	1/2" Wrench
Rubber Hammer	Spring Compression Tool	1/2" Socket and Ratchet
9/16" Wrench	9/16" Socket and Ratchet	OG2 Grease
Thread Locker (Medium Strength)		

Replacement Procedure:

1. Apply the stretcher brake. Raise litter to full height. Raise all rails to full up.

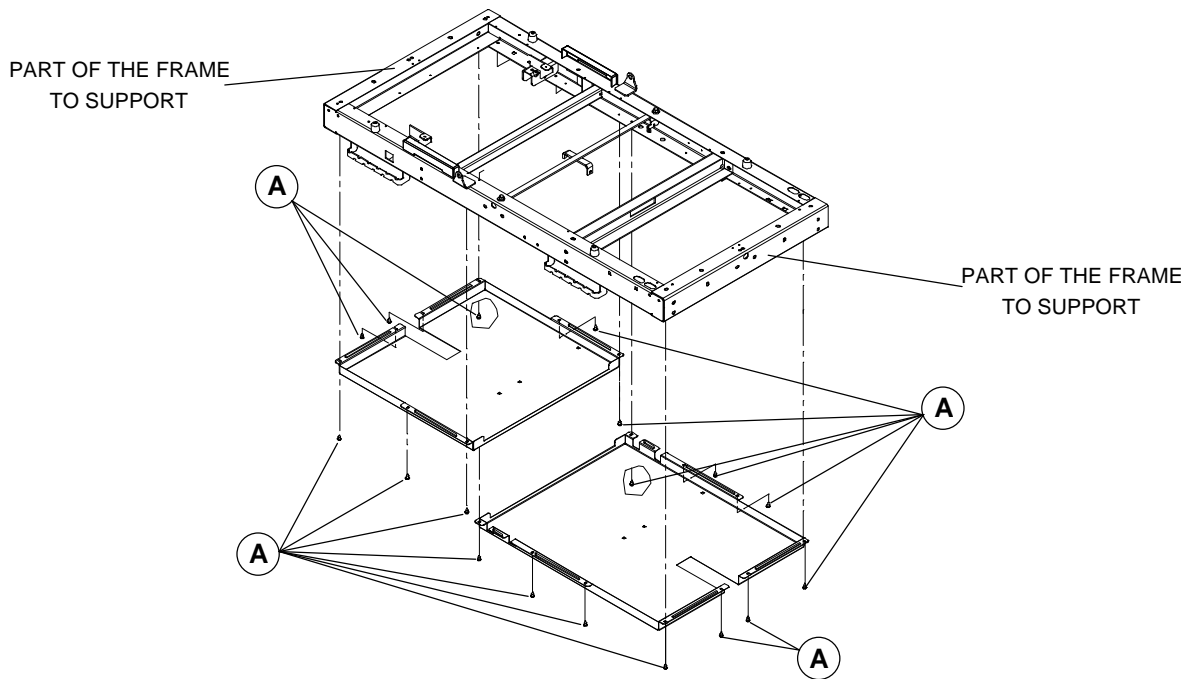

Figure 3.1A

2. Using a Phillips screwdriver, remove the 18 screws (A, fig. 3.1A) holding the lower head and foot cover plates. Remove the two cover plates.
3. Support both ends of the stretcher frame with appropriate supports (each must be capable of supporting at least 200 lb (91 kg)).

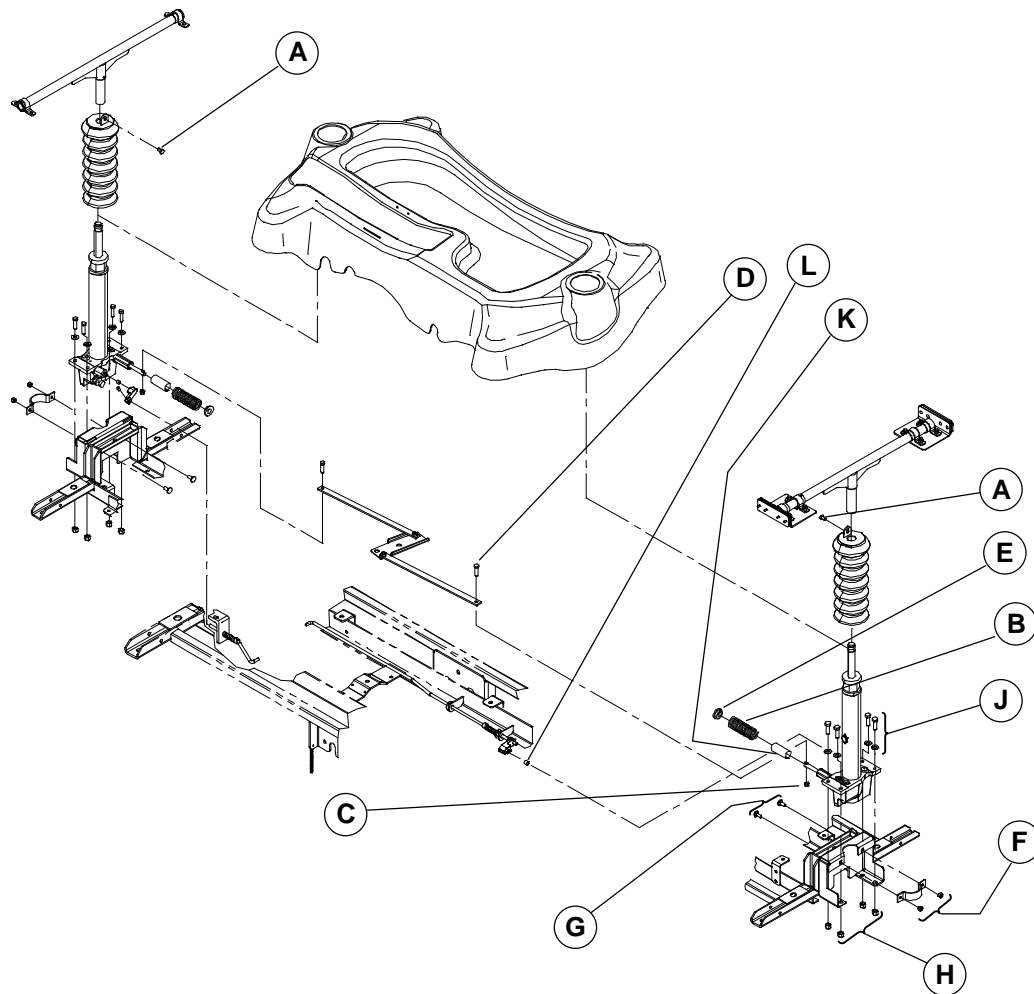

Figure 3.1B

4. Using a 1/2" wrench, remove the bolt (A) holding the litter support tube to the jack actuator rod on both ends. The bolt also holds the upper part of the black bellows.

NOTE

You may need to hammer the litter support tube to remove the actuator rod out of the tube. Use a rubber hammer.

Apply medium-strength thread locker on the bolt threads before re-assembly.

5. Lower the jacks to the full down position. The actuator must be manually lowered while the appropriate release pedal is depressed.
6. Remove the two black bellows.
7. Move the base from under the supported stretcher litter to an appropriate working area.
8. Lift off the plastic base hood, separating the Velcro holding it to the base frame.
9. Using a spring compression tool, compress the pump spring (B) of the jack needing replacement.
10. Using a 1/2" wrench and a 1/2" socket and ratchet, remove the locknut (C) and bolt (D) linking the activation bar to the pump piston.
11. Remove the spring (B) and shoulder socket (E) from the pump piston.

NOTE

Apply grease on the spring before reassembly.

12. Using a 1/2" wrench and 1/2" socket and ratchet, remove the two locknuts (F) and bolts (G) holding the jack clamp to the frame.

13. Using a 9/16" wrench and a 9/16" socket and ratchet, remove the four locknuts (H), washers and bolts (J) holding the jack base to the base frame. Support the jack base before removing the fasteners.
14. Pull the jack out. Proceed carefully as the release valve pin is still engaged in the descent lever. Keep the spring holder (K) and the safety stop (L) for the replacement jack.
15. Reverse steps 12-14 to install the replacement jack.
16. Replace the pump spring and activation bar using the spring compression tool.
17. Reinstall the base hood, the bellows, the stretcher litter and the cover plates.
18. Check jack for proper operation and adjust the jack descent rate (see the "Jack Descent Rate Adjustment", procedure 3.3, page 17).

NOTE

The stretcher jack descent rate was preset at the factory to lower the foot slightly faster than the head. It is recommended to have the foot end lower faster to avoid patient disorientation.

3.2 CHECKING HYDRAULIC FLUID LEVEL

Required Tools:

3/4" Wrench

Bungee Cords

Mobil Aero HFA Hydraulic Fluid

Procedure:

ITEM	PART NO.	PART NAME
A	45-966	O-Ring
B	45-967	O-Ring
C	390-2-134	Conical Comp. Spring
D	715-1-301	Base Plug
E	715-1-309	Valve Plug
F	715-1-341	Poppet
H	715-100-325	Pump Replacement Ass'y
J	926-20-153	Check Valve
K	926-20-154	Seal
L	926-20-156	Seal
M	1210-70-9	Valve Assembly
N	5050-70-50	P.C. Valve

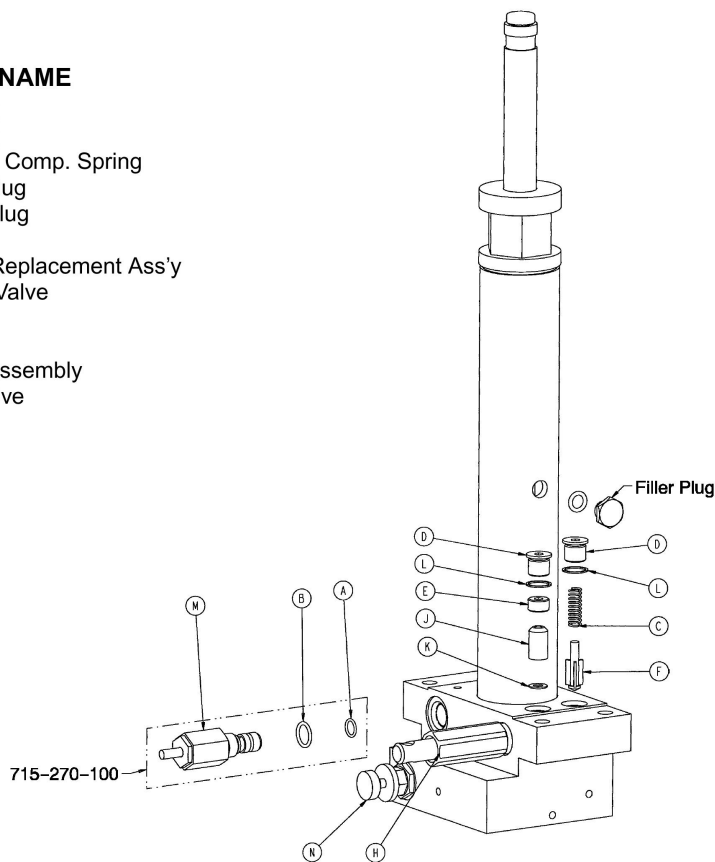

Figure 3.2

1. Apply the stretcher brake. Lower litter to full down position. Raise all rails to full up.
2. Be sure there are no hydraulic leaks. If there are, jack replacement will be necessary.
3. Remove bottom part of the bellows from the base hood, lift and support them using bungee cords to clear access to the filler plug.

4. Using a 3/4" wrench, slowly turn the filler plug located on the side of the reservoir counter clockwise to allow excess system pressure to vent. Remove the fill plug.
5. The hydraulic fluid should be visible at the bottom of the hole. If it is not, add Mobil Aero HFA hydraulic fluid (Stryker part number 2020-70-475) until the fluid is visible at the bottom of the fill hole. Replace the fill plug.

NOTE

Use of other types of oil may damage hydraulic units.

6. Verify the jack operation before reinstalling the bellows.

3.3 CONSTANT FLOW JACK DESCENT RATE ADJUSTMENT**Required Tools:**

Bungee Cords

Procedure:**NOTE**

Unless otherwise stated, reference letters contained in the following procedure will refer to figure 3.2, page 16.

The jack descent rate was preset at the factory to lower the foot slightly faster than the head. It is recommended to have the foot end lower faster to avoid patient disorientation.

1. Apply the stretcher brake. Raise all rails to full up. Pump the litter to full height.
2. Lift the base hood, separating the Velcro holding it to the base frame, and support it using bungee cords.
3. The adjustable descent valve is located on the base of the jack and has a blue knob on the end (N). To adjust, loosen the silver locking ring by turning it counter clockwise. Turning the blue knob (N) clockwise will increase the rate of litter descent. Turning it counter clockwise will decrease the rate of descent.
4. Adjust the valve so that the jack at the foot end of the stretcher will descend slightly faster than the jack at the head end.
5. Remove the bungee cords and replace the base hood.

3.4 REMOVING EXCESS AIR FROM THE HYDRAULIC SYSTEM

1. Verify all hydraulic linkages are secure and operating properly.
2. Using the pump pedal, actuate system several times. This will force the air through the system and the jack should now pump up.

3.5 HYDRAULIC VALVE REPLACEMENT

POPPET VALVE

Required Tools:

Bungee Cords	1/4" Allen Key	Small Needle Nose Pliers
Torque Wrench		

Procedure:

NOTE

Unless otherwise stated, reference letters contained in the following procedure will refer to figure 3.2, page 16.

1. Apply the stretcher brake. Lower litter to full down position. Raise all four rails to full up.
2. Lift the base hood, separating the Velcro holding it to the frame, and support it using bungee cords.

NOTE

Jack must be lowered completely to relieve the pressure on the pump piston side of the jack.

3. Using a 1/4" Allen key, remove the base plug (D) and the seal (L).
4. Remove the compression spring (C).
5. Using a small needle nose pliers, remove the poppet (F).
6. Install the new poppet valve (F).
7. Install the compression spring (C).
8. Install the seal (L) and the base plug (D) and tighten to 10 lbf-ft (13.5 N-m) torque.
9. Pump up the jack to the maximum height. Apply weight and ensure the jack holds its position and there are no hydraulic leaks before reinstalling the base hood.
10. Remove the bungee cords and reinstall the base hood.

CHECK VALVE

Required Tools:

Bungee Cords	1/4" Allen Key	Small Needle Nose Pliers
Stiff Wire (with bent, pointed end)	1/2" Diameter Rod	Torque Wrench

Procedure:

NOTE

Unless otherwise stated, reference letters contained in the following procedure will refer to figure 3.2, page 16.

1. Apply the stretcher brake. Lower litter to full down position. Raise all four rails to full up.
2. Lift the base hood, separating the Velcro holding it to the frame, and support it using bungee cords.

NOTE

Jack must be lowered completely to relieve the pressure on the pump piston side of the jack.

3. Using a 1/4" Allen key, remove the base plug (D) and the seal (L).
4. Using a 1/4" Allen key, remove the valve plug (E).
5. Using a stiff wire with a bent, pointed end, remove the check valve (J) and the seal (K).
6. Install the seal (K) flat to the bottom of its hole with a 1/2" diameter rod.

7. Install the new check valve (J) with the beveled end up (as shown in the illustration).
8. Install the valve plug (E) and tighten to 10 lbf-ft (13.5 N-m) torque.
9. Install the seal (L) with the base plug (D) and tighten to 10 lbf-ft (13.5 N-m).
10. Pump up the jack to maximum height. Apply weight and ensure the jack holds its position and there are no hydraulic leaks before reinstalling the base hood.
11. Remove the bungee cords and reinstall the base hood.

3.6 ADJUSTABLE PRESSURE COMPENSATED (P.C.) VALVE REPLACEMENT

Required Tools:

13/16" Wrench

Bungee Cords

Procedure:

NOTE

Unless otherwise stated, reference letters contained in the following procedure will refer to figure 3.2, page 16.

1. Apply the stretcher brake. Lower litter to full down position. Raise all four rails to full up.
2. Lift the base hood, separating the Velcro holding it to the frame, and support it using bungee cords.

NOTE

Jack must be lowered completely to relieve the pressure on the pump piston side of the jack.

3. Using a 13/16" wrench, remove the adjustable P.C. valve (N).
4. Check for any contaminants in the valve as well as in the jack base.
5. Install the replacement P.C. valve (N). Moisten the O-ring seal with hydraulic fluid to ensure a tight seal.
6. Tighten the valve manually and then add an additional 1/8-1/4 turn with a 13/16" wrench. **Do not over-tighten** or damage may occur to the O-ring seal.
7. Pump up the jack to the maximum height and fully lower it to verify proper operation.
8. Check for any hydraulic fluid leaks before reinstalling the base hood.
9. Remove the bungee cords and reinstall the base hood.

3.7 FIFTH STEER WHEEL COMPONENT REPLACEMENT

NOTE

Depending on the repair equipment available, the litter assembly removal of a fixed height stretcher may be necessary to reach the fifth steer wheel mechanism. To do so, perform the "Litter Assembly Removal" procedure below.

Access to the fifth wheel mechanism of an hydraulic stretcher is easier but if more working room is needed, the litter assembly may also be removed. Refer to step one through eight (inclusive) of procedure 3.1, page 14 to remove the litter assembly of an hydraulic stretcher.

When available repair equipment allows easy access to the fifth wheel mechanism on either stretcher model, ignore the "Litter Removal" procedure and proceed directly with the appropriate replacement procedure.

LITTER ASSEMBLY REMOVAL - FIXED HEIGHT STRETCHER

Required Tools:

- | | | |
|----------------------|--------------|-----------------|
| Phillips Screwdriver | Bungee Cords | 1/2" Wrench (2) |
| Trestles (2) | Supports (2) | |

Procedure:

NOTE

It requires at least two people to safely perform this procedure. The litter frame assembly may weigh up to 200 lb (91 kg).

1. Apply the brake on all four casters. Raise all four rails.
2. Remove the 18 screws (A, fig. 3.1A, page 14) holding the two lower cover plates to the litter frames. Remove cover plates.
3. Lift the black bellows and support them using bungee cords.
4. Support both ends of the stretcher with appropriate supports (each must be capable of supporting at least 200 lb (91 kg)).

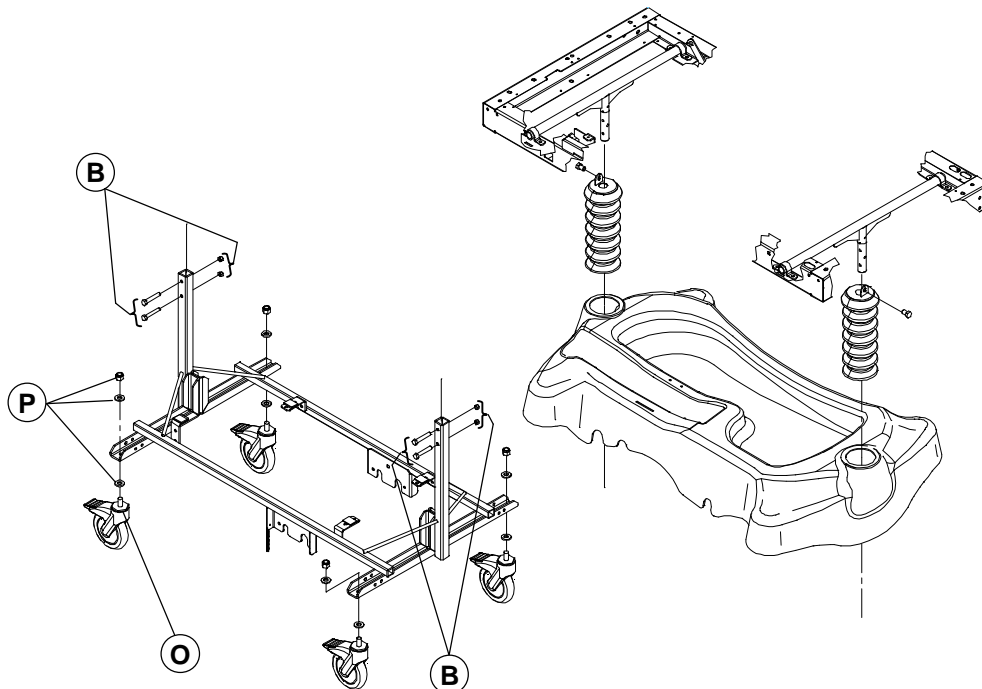

Figure 3.7

5. Using two 1/2" wrenches, remove the four bolts and locknuts (B) holding the litter support tubes to the base posts. If the bolts are stuck, slightly raise the litter end to ease their removal.
6. With the help of another person, lift off the litter and set it aside on trestles. Each trestle should be capable of supporting at least 200 lb (91 kg).
7. Remove the base hood, separating the Velcro holding it to the base frame.
8. You are now ready to work on the fifth wheel mechanism.

WHEEL ARM ASSEMBLY

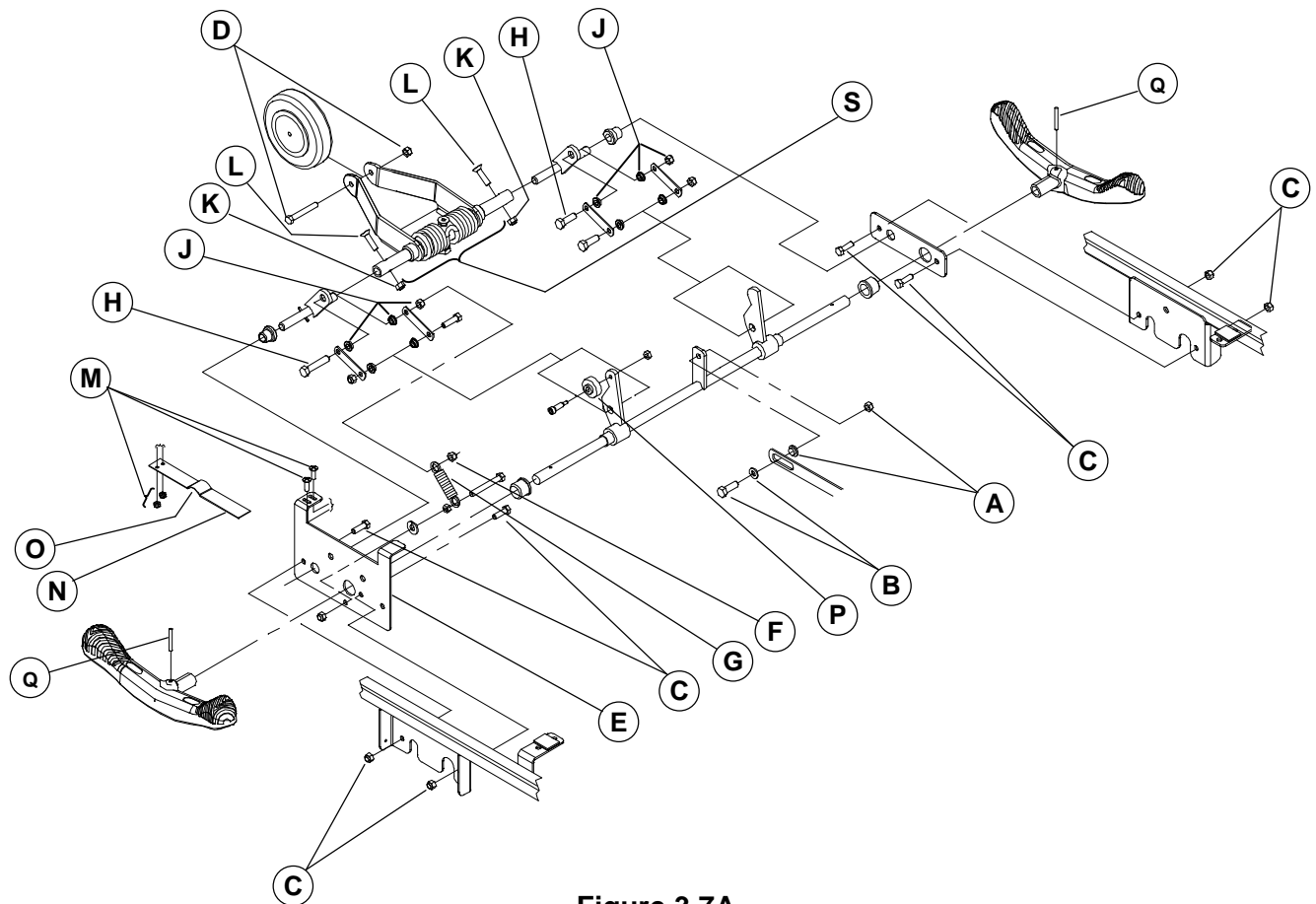

Figure 3.7A

Required Tools:

Bungee Cords

1/2" Wrench (2)

3/16" Allen Key

1/2" Socket and Ratchet

Procedure:

1. Raise the litter to full height (hydraulic model). Raise all four rails to full up.
2. Lift the base hood, separating the Velcro holding it to the frame, and support it using bungee cords.

NOTE

If the stretcher needing repair is an hydraulic model, continue with step three, otherwise (fixed height model) ignore step three and resume procedure with step four.

3. Using two 1/2" wrenches, remove the locknut/nylon shoulder washer (A), and the flat washer/bolt (B) holding the connecting rod to the brake pedal shaft.

- Using a 1/2" wrench and a 1/2" socket and ratchet, remove the four locknuts/bolts (C) holding the fifth wheel to the support plates. Lower the assembly to the ground and remove it from under the base frame. Lay assembly on a workbench.
- Using two 1/2" wrenches, remove the locknut and bolt (D) holding the caster to the wheel arm. Remove the caster.
- Move the left support plate (E) towards the brake/steer pedal to disengage the swing arm and torsion lever assembly from the support plates.
- Using a 1/2" wrench, remove the locknut (F) retaining the spring hook (G) to the bolt (H).
- Using two 1/2" wrenches, remove the two locknuts/shoulder spacers(4) (J) and bolts (H) holding the top part of the counter-levers to both fifth wheel torsion levers.
- Using a 1/2" wrench and a 3/16 Allen key, remove the two locknuts (K) and the socket cap screws (L) holding the torsion levers to both ends of the fifth wheel shaft.

NOTE

Carefully note the torsion lever (mark their position) positions relatively to the fifth wheel shaft to properly reinstall them.

Be sure the socket cap screws (L) are tightly screwed down before tightening the locknuts (K).

- Remove the defective wheel arm assembly (S).
- Mount the fifth wheel on the new wheel arm assembly.
- Reverse the above steps to install the new wheel arm assembly and reinstall the fifth wheel assembly on the base frame.
- Verify the fifth wheel is operational with the steer pedal engaged before reinstalling the base hood.

FIFTH WHEEL CASTER

Required Tools:

1/2" Wrench (2) Bungee Cords

Procedure:

NOTE

Unless otherwise stated, reference letters contained in the following procedure will refer to figure 3.7A, page 21

- Raise the litter to full up (hydraulic model). Apply the stretcher brake. Raise all four rails to full up.
- Lift the base hood, separating the Velcro holding it to the frame, and support it using bungee cords.
- Using two 1/2" wrenches, remove the locknut and bolt (D) holding the caster to the wheel arm. Remove the defective caster.
- Install the new caster.
- Remove the bungee cords and reinstall the base hood.

NEUTRAL GUIDE PLATE**Required Tools:**

Bungee Cords

3/8" Wrench

Phillips Screwdriver

Procedure:**NOTE**

Unless otherwise stated, reference letters contained in the following procedure will refer to figure 3.7A, page 21.

1. Apply the stretcher brake. Raise all four rails. Raise litter to full height (hydraulic base).
2. Lift the base hood, separating the Velcro holding it to the frame, and support it using bungee cords.
3. Using a Phillips screwdriver and a 3/8" wrench, remove the two locknuts/screws (M) holding the neutral guide plate (N) to the left support plate.
4. Remove the defective guide plate.
5. Install the new guide plate and adjust its mounting position by first positioning the steer pedal to the neutral position and then aligning the guide plate cavity (O) with the neutral guide wheel (P). Tighten the fasteners.
6. Verify the neutral guide plate operates properly when the pedal is toggled to neutral position before reinstalling the base hood.

BRAKE/STEER PEDAL**Required Tools:**

3/16" Drive Pin

Hammer

Wheel Blocks

Procedure:**NOTE**

Unless otherwise stated, reference letters contained in the following procedure will refer to figure 3.7A, page 21.

1. Immobilize the hydraulic stretcher with wheel blocks or lock the fixed height stretcher casters. Raise all four rails to full up. Raise litter to full height (hydraulic stretcher).
2. Position the brake/steer pedal to neutral position.
3. Using a hammer and 3/16" drive pin, remove the spring pin (Q) holding the pedal to the pedal shaft.
4. Remove the pedal from the pedal shaft (use of a hammer may be required).
5. Fit the replacement pedal on the pedal shaft taking care to align the pedal and the pedal shaft holes.
6. Using a hammer, drive the spring pin in until it is flush to the top of the pedal.
7. Verify the pedal operation to ensure unit functions properly in the brake, neutral and steer modes.

3.8 BRAKE BAR REPLACEMENT - HYDRAULIC STRETCHER

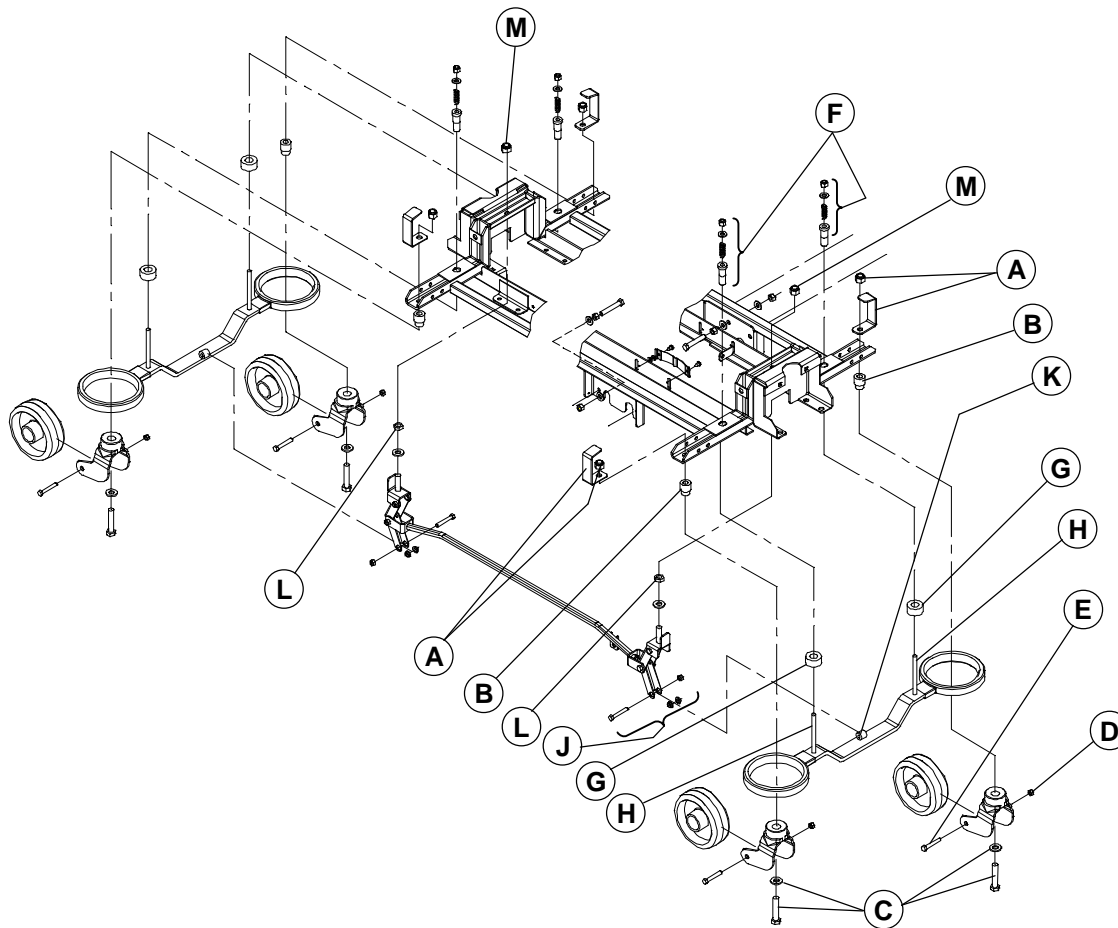

Figure 3.8

Required Tools:

- | | | |
|--------------------------------|--------------|-------------------------|
| Floor Jack | Bungee Cords | 3/4" Socket and Ratchet |
| 3/4" Angled Socket and Ratchet | | 5/8" Wrench |
| 11/16" Socket and Ratchet | 9/16" Wrench | 1/2" Wrench (2) |
| | | OG2 Grease |

Procedure:

1. Raise litter to full height. Raise all four rails to full up.
2. Use a floor jack to raise the end of the base frame needing repair approximately 9" from the floor and support the base frame with 9" blocks. Remove the jack stand. Casters should be 2 1/2" off the floor.
3. Lift the base hood, separating the Velcro holding it to the frame, and support it using bungee cords.
4. Using a 3/4" socket and ratchet and a 3/4" angled socket and ratchet, remove the two locknuts/base hood supports (A), caster adjusting sockets (B) and washers/bolts (C), holding the two casters to the base frame. Remove casters.

NOTE

Reaching the caster bottom bolt may be difficult without the adequate tool. Removing the caster wheel will clear access to this bolt. Use a 5/8" wrench and an 11/16" socket and ratchet to remove the nut (D) and bolt (E) holding the wheel to the caster horn and remove the wheel.

For a fixed height stretcher, proceed with step 4 and 5 only.

For an hydraulic stretcher, go to step 6.

4. While holding the caster stem (O, fig. 3.7, page 20) with a special tool available through our Technical Service department (P/N 19-0803-Z), use a 3/4" socket and ratchet to remove the locknut/washers(2) (P, fig. 3.7, page 20) holding the caster to the base frame. Remove the defective caster.
5. Install the replacement caster, lower the stretcher to the ground and verify the replacement wheel before reinstalling the base hood.

End of procedure.

6. Using a 3/4" socket and ratchet and a 3/4" angled socket and ratchet, remove the locknut/base hood support (A, fig. 3.8, page 24), caster adjusting sockets (B, fig. 3.8, page 24) and washer/bolt (C, fig. 3.8, page 24), holding the caster assembly to the base frame. Remove the defective caster.

NOTE

Reaching the caster assembly bottom bolt may be difficult without the adequate tool. Removing the wheel will clear access to this bolt. Use a 5/8" wrench and an 11/16" socket and ratchet to remove the nut (D, fig. 3.8, page 24) and bolt (E, fig. 3.8, page 24) holding the wheel to the caster horn and remove the wheel.

7. Install the replacement caster assembly, lower the stretcher to the ground and test its operation before reinstalling the base hood.

3.11 HYDRAULIC BASE PEDAL REPLACEMENT

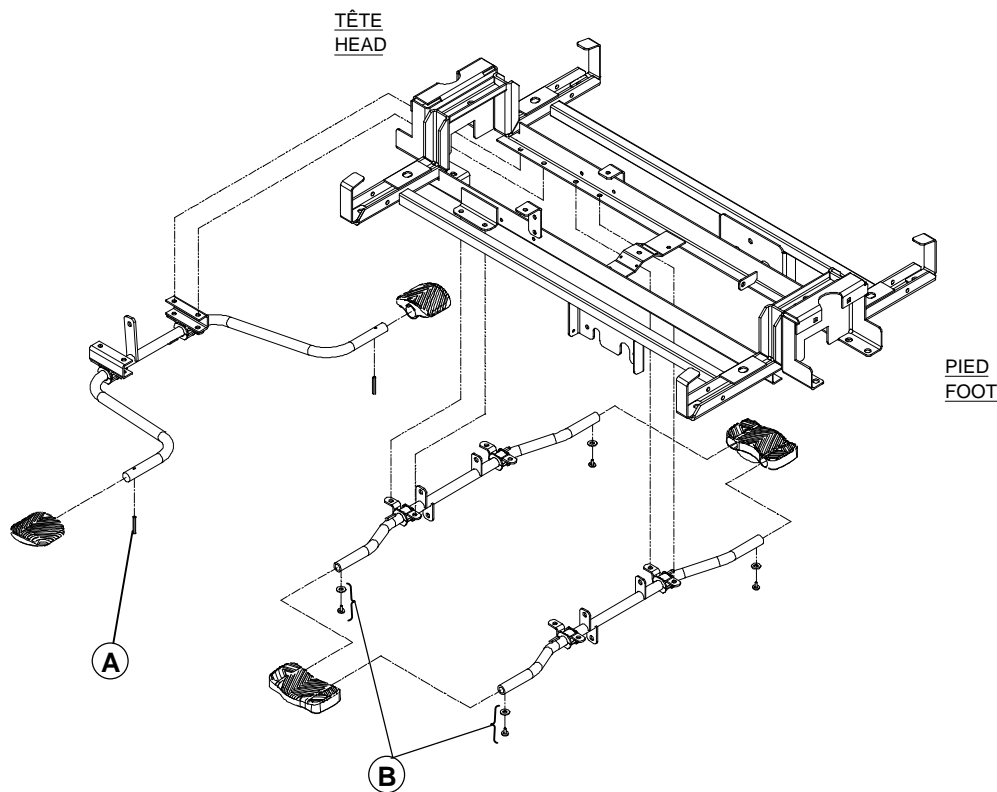

Figure 3.11

NOTE

Unless otherwise stated, reference letters contained in the two following replacement procedures will refer to figure 3.11 above.

3.12 PNEUMATIC ASSIST FOWLER COMPONENT REPLACEMENT

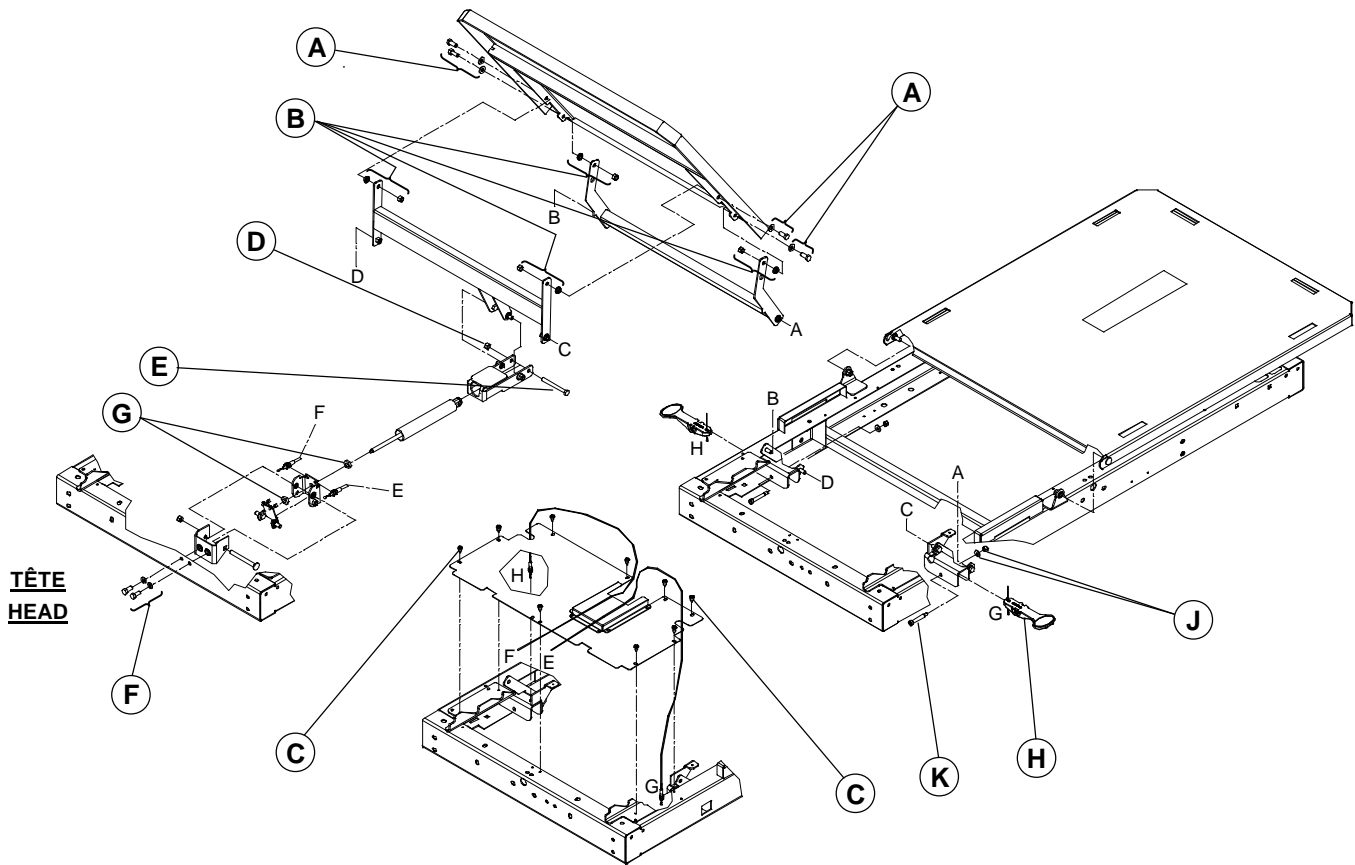

Figure 3.12

NOTE

Unless otherwise stated, the reference letters contained in all the replacement procedures detailed in section 3.12 will refer to figure 3.12 above.

HEAD SECTION

Required Tools:

1/2" Wrench (2)

Bungee Cords

Procedure:

1. Apply the stretcher brake. Lower rails to full down. Raise the fowler completely and support it using bungee cords.
2. Using two 1/2" wrenches, remove the four locknuts/shoulder spacers (A) and the washers/bolts (B) holding the head section to the two coupling bars.
3. Remove the defective head section and install the new one. Remove the bungee cords.
4. Verify the head section for proper operation.

PNEUMATIC CYLINDER

Required Tools:

1/2" Wrench (2)

Phillips Screwdriver

11/16" Wrench

Procedure:

1. Apply the stretcher brake. Lower rails to full down. Raise the Fowler completely.
2. Using two 1/2" wrenches, remove the four locknuts/shoulder spacers (A) and the washers/bolts (B) holding the head section to the two coupling bars.
3. Using a Philips screwdriver, remove the nine screws (C) holding the protective plate to the litter frame.
4. Using two 1/2" wrenches, remove the locknut (D) and bolt (E) holding the cylinder end to the bracket.
5. Using a 1/2" wrench, remove the two bolts/washers (F) holding the cylinder bracket to the litter frame.

NOTE

Apply medium strength thread locker on the bolt (F) threads before re-assembly.

6. Move the whole assembly slightly toward the centre of the stretcher and using an 11/16" wrench, remove the two nuts (G) holding the cylinder threaded extremity to the bracket. Remove the defective cylinder.

NOTE

Apply medium strength thread locker on the nut (G) threads before re-assembly.

7. Install the new cylinder. Adjust the two nut (G) positions so that the cylinder release pin will press the activation flap enough to tighten the two Fowler release cables without activating the release pin.
8. Reinstall the cylinder assembly and the head section.
9. Test the pneumatic Fowler for proper operation before reinstalling the protective plate. If the Fowler operates erratically, adjust consequently the nut (G) positions.

FOWLER ASSIST CABLE

Required Tools:

Phillips Screwdriver

7/16" Wrench (2)

Procedure:

1. Apply the stretcher brake. Lower rails to full down. Raise the fowler completely.
2. Using a Philips screwdriver, remove the nine screws (C) holding the protective plate to the litter frame.
3. Using two 7/16" wrenches, loosen the two nuts at both ends of the defective cable to enable its removal. Carefully note how the cable extremities are mounted at their tie points. Remove the defective cable.

NOTE

Carefully note the cable path to properly replace the cable at reassembly.

4. Install the new cable.
5. Adjust the two nuts at each cable end so that, 1: the adjustment at the activation lever end leaves no play in the activation lever, 2: the adjustment at the activation flap end presses the activating flap against the cylinder release pin without activating it.
6. Verify the Fowler for proper operation before reinstalling the protective plate.

FOWLER ACTIVATION LEVER

Required Tools:

Phillips Screwdriver

7/16" Wrench (2)

5/32" Allen key

Procedure:

1. Apply the stretcher brake. Lower rails to full down. Raise the Fowler to full height.
2. Using two 7/16" wrenches, loosen the two nuts holding the cable end to the activation lever (H). Remove cable from the activation lever.
3. Using a 5/32" Allen key and a 7/16" wrench, remove the locknut/washer (J) and shoulder screw (K) holding the activation lever to the litter frame. Remove the defective activation lever.
4. Install the new activation lever. Reinstall the cable end into the lever.
5. The cable end nuts must be adjusted for the Fowler to operate properly. Adjust the two nuts so that no play is left in the activation lever (see step 4 of the preceding procedure "Fowler Release Cable Replacement").

3.13 MANUAL FOWLER COMPONENT REPLACEMENT

HEAD SECTION

To replace the head section, refer to the assisted Fowler "Head Section" replacement procedure, page 28.

HEAD SUPPORT ARM

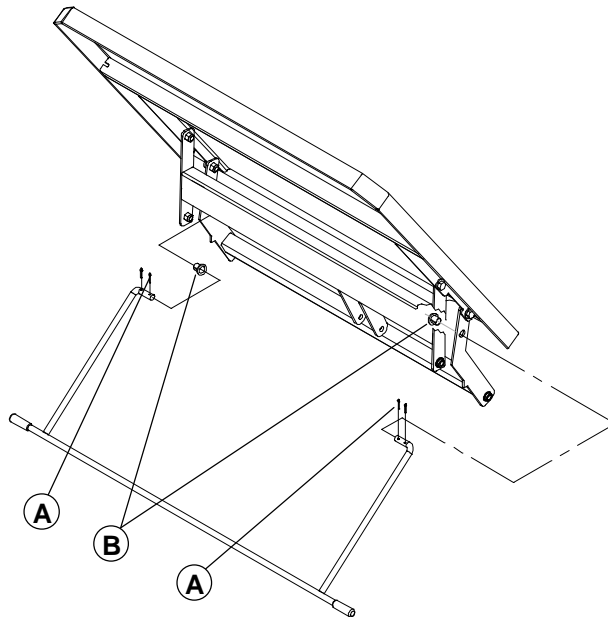

Figure 3.13

Required Tools:

Long Nose Pliers

Bungee Cords

Procedure:

1. Apply the stretcher brake. Lower rails to full down. Raise the Fowler completely and support it using bungee cords.

2. Using long nose pliers, remove the two inner cotter pins (A) holding in place the support arm.
3. Remove the defective support arm. Keep the nylon shoulder bushings (B). Replace if damaged.
4. Install the new support arm and verify it operates properly.

3.14 SIDE/END RAIL COMPONENT REPLACEMENT

HANDLE ASSEMBLY

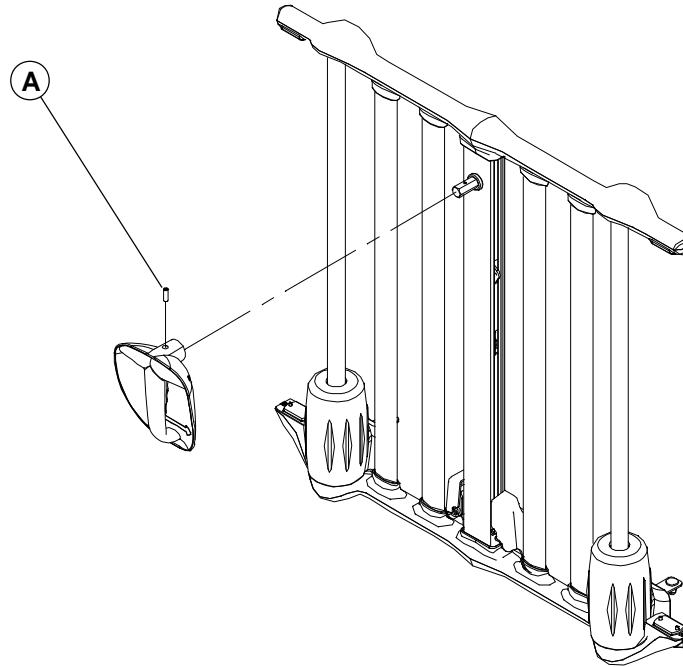

Figure 3.14A

Required Tools:

3/32" Allen Key

Procedure:

1. Apply the stretcher brake. Raise the rail needing repair to full up.
2. Using a 3/32" Allen Key, remove the set screw (A) holding the handle assembly to the shaft. Remove the handle assembly.
3. Install the new handle assembly and verify the trigger, the rotating movement and the locking of the rail at the 9", 14" and upper position, for proper operation.

CENTRAL COLUMN ASSEMBLY



WARNING

The dismantling and reassembly of a central column inner mechanism is a complex and precise task requiring a thorough knowledge of the product. It must not be attempted without first seeking guidance from the Technical Service department (see section 1.2).

Disregarding this warning could result in serious injury to the patient or user.

NOTE

When ordering a central column, please specify if the bed is equipped with the double safety lock at the 9" position. Beds without this feature have a warning affixed to the central column indicating the rail can be lowered below the mattress surface without stopping.

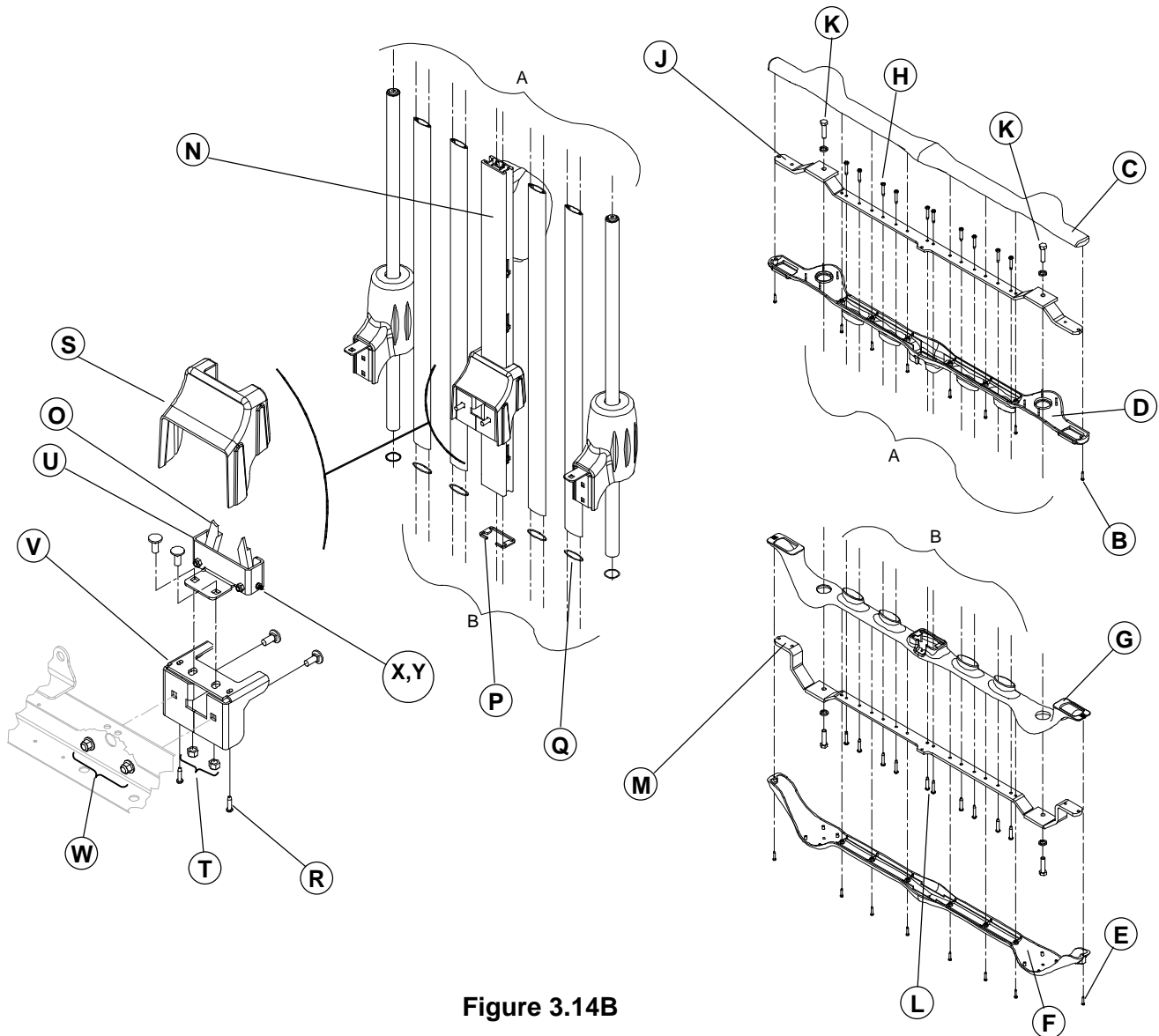

Figure 3.14B

Required Tools:

Phillips Screwdriver

3/32" Allen Key

Knife

3/8" Wrench

1/2" Socket and Ratchet

Procedure:

1. Apply the stretcher brake. Raise the rail needing repair to full up.
2. Using a 3/32" Allen Key, remove the set screw (A, fig 3.14A, page 31) holding the handle assembly to the shaft. Remove the handle assembly.
3. Using a Phillips screwdriver, remove the eight screws (B) holding the rail upper plastic cover (C) to its lower counterpart (D). If working on a siderail, open the access doors to reach the last screw on each end of the lower plastic cover. Note that on a siderail with fixed access doors, these two last screws are not present.

NOTE

Remove the upper cover carefully to avoid damaging the lower cover snap fit pins.

4. Using a Phillips screwdriver, remove the eight screws (E) holding the rail bottom plastic cover (F) to its upper counterpart (G). If working on a siderail, open the access doors to reach the last screw on each end of the upper plastic cover. Note that on a siderail with fixed access doors, these two last screws are not present.

NOTE

Remove the bottom cover carefully to avoid damaging the upper cover snap fit pins.

5. Using a Phillips screwdriver, remove the siderail (10) or endrail (14) screws (H) holding the rail posts and central column to the upper structural member (J).
6. Using a 1/2" socket and ratchet, remove the bolts/washers (K) holding the two sliding guide posts to the structural member.
7. Remove the upper structural member (J) and the bottom plastic cover (D).

NOTE

If replacing the central column of a siderail, help will be needed to hold and remove the access doors while the upper structural member and the plastic cover will be removed. The access door upper hinges are part of the structural member, only the bottom part of the access doors will be supported as the upper structural member is removed.

NOTE

At reassembly, make sure the access doors operate properly after having mounted the upper structural member and before fastening the upper plastic covers.

8. Using a Phillips screwdriver, remove the two screws (L) holding the bottom part of the central column to the lower structural member (M).
9. Gently remove the central column (N), disengaging it from the stop catches (O). Be sure the central column seal (P) remains in place when the column is removed.

NOTE

Be sure the O-ring seals (Q) located at the bottom of the posts are properly seated when reassembling the rail.

10. Reverse the above steps to install the new central column. Reinstall the handle.
11. Check the stop catch (O) positions, and, if needed (see note below), adjust them by following steps 11.1 to 11.4.

NOTE

The right adjustment is obtained when the stop catches are laterally and longitudinally centered. The lateral positioning distributes the stop catch blocking surfaces equally under the fixed stoppers and prevent them from rubbing against the inner face of the plastic extrusion. The longitudinal positioning prevents the stop catches from rubbing against the inner sides of the plastic extrusion. Fine-tuning of the lateral position of the stop catches is also available through adjustment screws located on both sides of the brake shoe support.

- 11.1. Using a Phillips screwdriver, remove the two screws (R) holding the brake shoe cover (S) to the brake shoe support. Remove the cover.

- 11.2. Using a 1/2" socket and ratchet, loosen the two locknuts (T) holding the brake shoe (U) to the brake shoe support (V) and the two locknuts (W) holding the support to the litter frame.
 - 11.3. Move the brake shoe (U) back and forth (longitudinal) and the brake shoe support (V) sideways (lateral) to properly position the stop catches (O). Tighten the locknuts.
 - 11.4. To laterally fine-tune the stop catch position, loosen the locknut (X) using a 3/8" wrench and screw out the adjustment screw (Y) using a 3/32" Allen key until the stop catch is properly positioned. This is especially needed when one or both stop catches still rub against the inner face of the plastic extrusion.
12. Verify the handle and the four rail positions, i.e. down, 9", 14" and 26" (highest) for proper operation before reinstalling the brake shoe cover.

RAIL UPPER/LOWER COVER

Required Tools:

Phillips Screwdriver

Procedure:

NOTE

Unless otherwise stated, reference letters contained in the following procedure will refer to figure 3.14B, page 32.

1. Apply the stretcher brake. Raise the rail needing repair to full up.
2. **Upper Cover:** Using a Phillips screwdriver, remove the eight screws (B) holding the rail upper plastic cover (C) to its lower counterpart (D). If working on a siderail, open the access doors to reach the last screw on each end of the lower plastic cover. Note that on a siderail with fixed access doors, those two last screws are not present.

Lower Cover: Using a Phillips screwdriver, remove the eight screws (E) holding the lower plastic cover (F) to its upper counterpart (G). If working on a siderail, open the access doors to reach the last screw on each end of the upper plastic cover. Note that on a siderail with fixed access doors, those two last screws are not present.

NOTE

Remove the cover carefully to avoid damaging the snap fit pins of the cover lower or upper counterpart.

3. Install the new plastic cover taking care that the cover receptacles match their corresponding snap fit pins in the cover lower or upper counterpart.

RAIL SUPPORT ROLLING BEARING

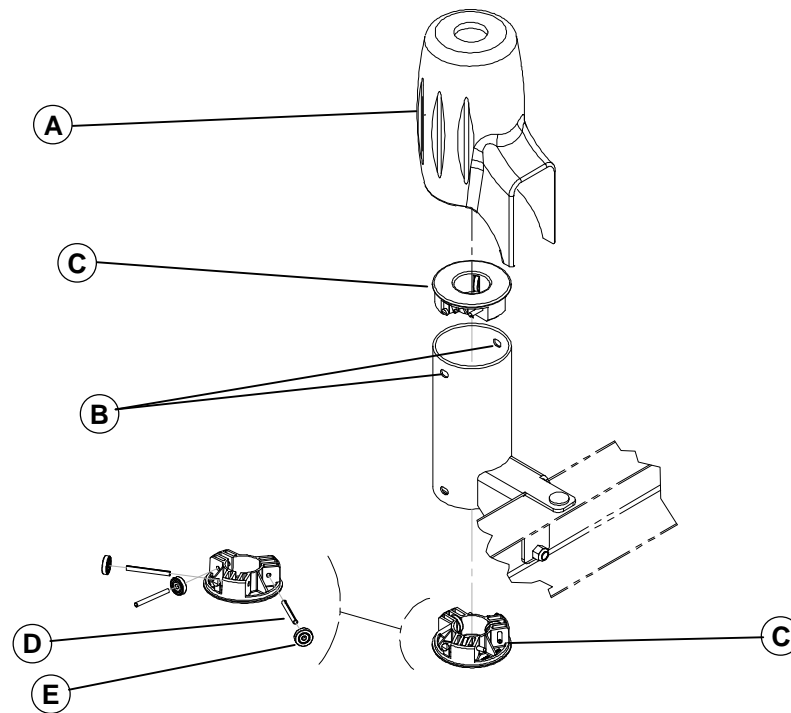

Figure 3.14C

Required Tools:

Slotted Screwdriver

Long Nose Pliers

Ø1/8" Punch

Bungee Cords

Procedure:

1. Apply the stretcher brake. Raise the Fowler or the foot section (if necessary, support it with bungee cords) and remove any accessory brackets present if working on a head or foot endrail.
2. If repairing the upper set of rolling bearings, raise the rail completely.
If working on the lower set of rolling bearings, lower the rail to the 9" position.
3. Lift the rail support cover (A). Support it using a bungee cord when the rail is in the upper position.

NOTE

The covers are tightly fit. Slightly lift each side of the plastic cover alternatively until completely removed.

4. Using a slotted screwdriver, press and lift the locking tab through the holes (B) located on both sides of the rail support to disengage the rolling bearing support (C) from its location.
5. Using long nose pliers, remove the spring pin (D) holding the rolling bearing (E). Remove the defective rolling bearing.
6. Using a Ø1/8" punch as a guide, insert the spring pin and the new rolling bearing in the support holes. Make sure the spring pin is centered, otherwise the rolling bearing assembly will not fit into the rail support.
7. Reinstall the rolling bearing support and the rail support cover .
8. Verify the rail for proper operation.

RAIL ASSIST CABLE



WARNING

Never replace the original assist cable by another type of cable or severe injury to the patient or user and damage to the stretcher may occur. The original cable (Part Number 19-0381) is available through our Technical Service department (see section 1.2).

Required Tools:

Phillips Screwdriver

Vise Grip (2)

Knife

Procedure:

1. Apply the stretcher brake. Raise the rail needing repair to full up.
2. Depending on the rail needing repair, lift and fold the foot section toward the head end of the stretcher or remove the head section to clear the way (see the "Head Section Replacement" procedure, page 28).

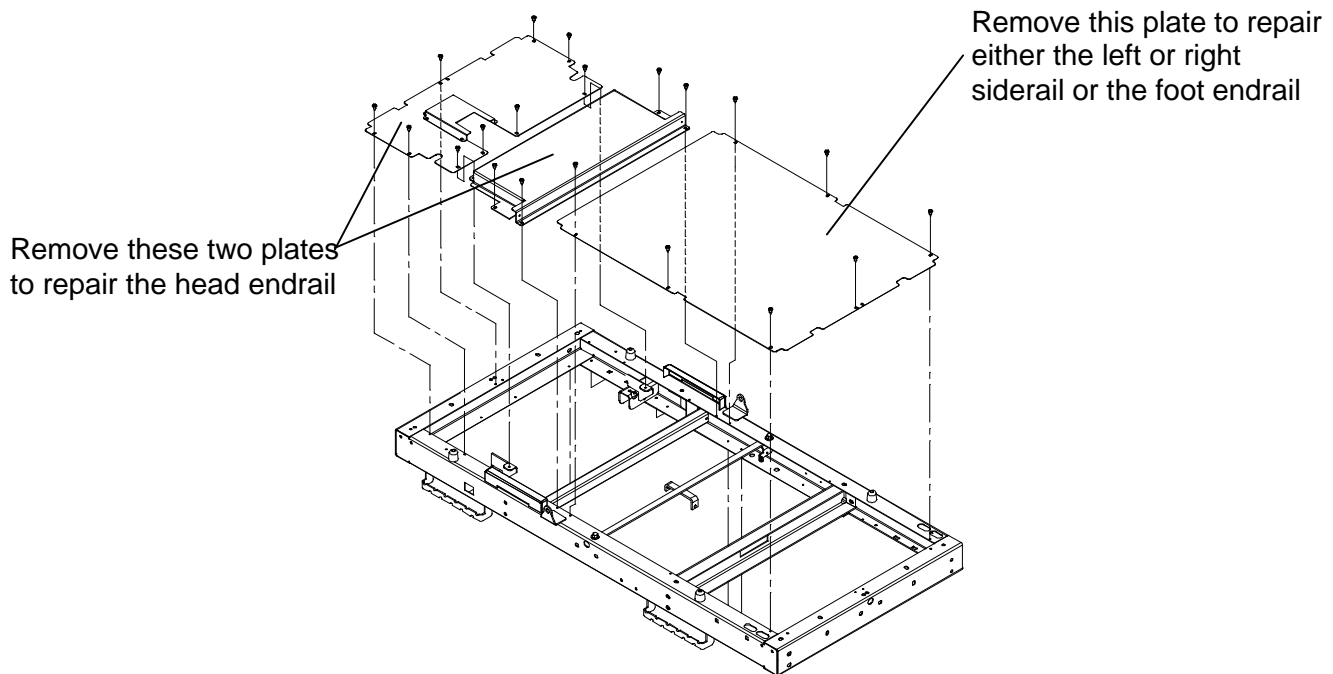

Figure 3.14D

3. Use a Phillips screwdriver to remove the screws holding the foot or head protective plate to the frame. Refer to figure 3.14D above to remove the appropriate plate.
4. Using a Phillips screwdriver, remove the eight screws (E, fig. 3.14B, page 32) holding the rail bottom plastic cover to its upper counterpart. If working on a siderail, open the access doors to reach the last screw on each end of the upper plastic cover. Note that on a siderail with fixed access doors, these two last screws are not present.

NOTE

Remove the bottom cover carefully to avoid damaging the upper cover snap fit pins.

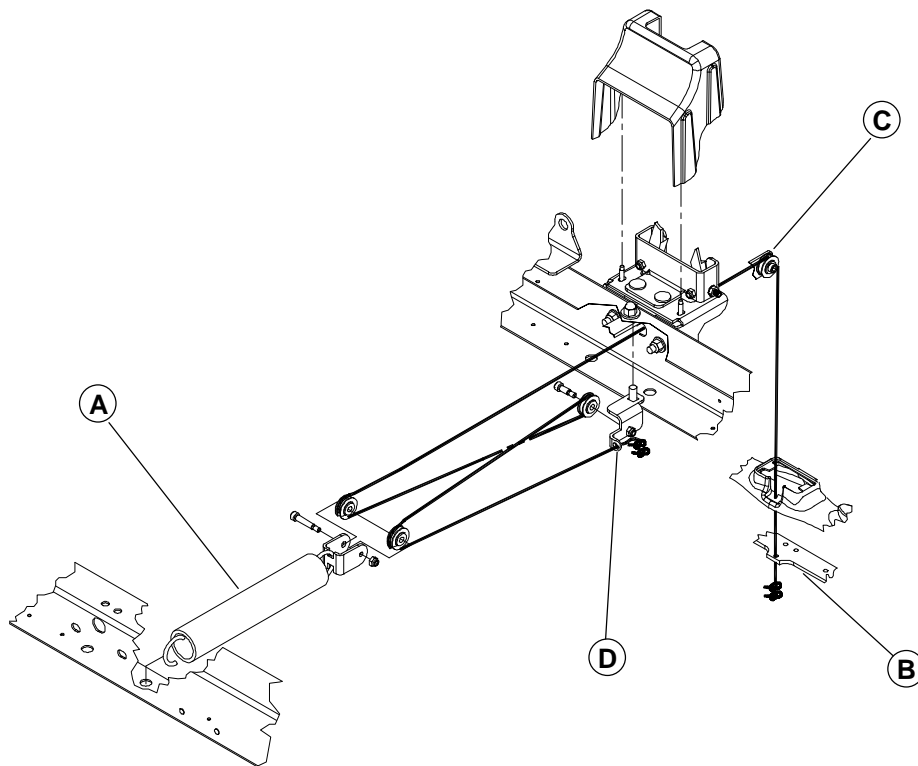

Figure 3.14E

5. Seize the cable, cut it and gently release the spring (A) to its rest state. Remove the defective cable. Note that the cable path begins underneath the lower structural member (B).

NOTE

Note carefully the complete cable path before removing it and refer to the drawings related to Parts List OL190019 or OL190020 to properly replace it at reassembly.

6. Make two solid knots at one end of the new cable and pass the other end through the hole located in the center of the rail lower structural member (B) and into the first pulley (C). The rail will have to be slightly lowered to do so.
7. Raise and lock the rail in the highest position and install the cable through the other pulleys and into the hole provided in the fixed pulley support (D) at the other end of its path. Hold it there using a pair of vise grip.
8. The cable first retaining knot position must now be found to finalize the cable installation. The following step describes the operation.
9. The rail still being locked at the upper position, pull the cable using the vise grip and hold it tight against the fixed pulley support (D) using a second pair of vise grip. Do not pull too much on the cable, the rail must be able to lower on a distance of approx. 9". Unlock the rail using the handle and let it fall down. Raise the rail and again let it fall down by unlocking it. Repeat this operation several time. The distance traveled by the falling rail will lengthen but will finally come to a stop following the cancellation of the cable elongation factor (the cable lengthens by 2 to 3 inches).
10. Once the cable maximum elongation attained, find the position of the first retaining knot by pulling and holding the cable in different positions using vise grips, until the rail lowers smoothly and reaches the 14" position without banging and locking. When the appropriate position is found, mark the cable right next to the support orifice for the first knot position and make the knot. Test once more before tightening the knot to make sure the position found is appropriate. Make another knot right after the first one. Tighten the knots and cut excess cable.
11. Verify the rail assist system for proper operation before replacing the bottom plastic cover and the protective plate(s).

3.15 ACCESS DOOR COMPONENT REPLACEMENT

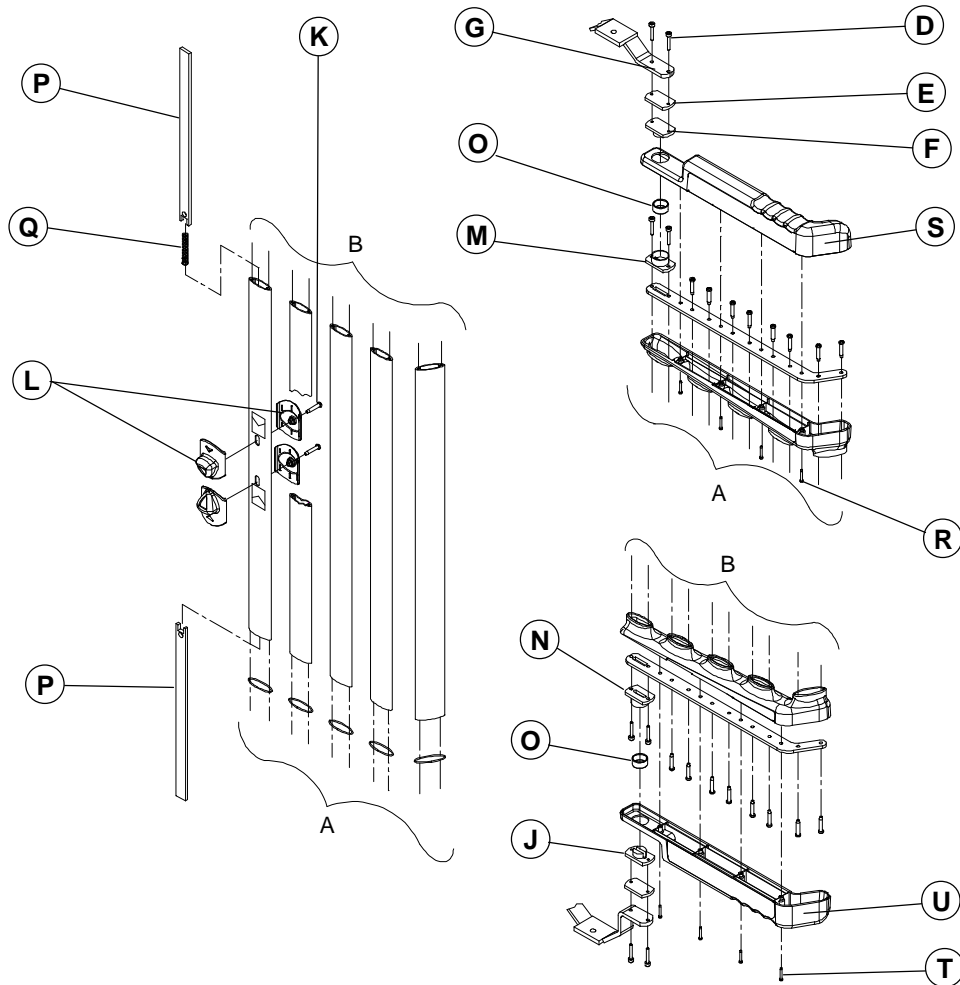

Figure 3.15

NOTE

Unless otherwise stated, reference letters contained in the following replacement procedures will refer to figure 3.15 above.

HINGE AND LATCH MECHANISMS COMPONENT

Required Tools:

- | | | |
|----------------------|-------------------------------|-------------|
| 5/32" Allen Key | Medium Strength Thread Locker | 1/2" Wrench |
| Phillips Screwdriver | OG2 Grease | |

Procedure:

1. Apply the stretcher brake. Raise the siderail needing repair to full up.
2. Using a Phillips screwdriver, remove the eight screws (A, fig. 3.14B, page 32) holding the siderail upper plastic cover (B, fig. 3.14B, page 32) to its lower counterpart (C, fig. 3.14B, page 32). Open the access doors to reach the last screw on each end of the lower plastic cover. Note that on siderails with fixed access doors, those two last screws are not present.

NOTE

Remove the upper cover carefully to avoid damaging the lower cover snap fit pins.

3. Using a 5/32" Allen key, remove the two screws (D) holding the spacer (E) and the outer hinge (F) to the structural member.

NOTE

Apply medium strength thread locker on the screw threads at reassembly.

4. Using a 1/2" wrench, loosen the bolt (H, fig. 3.14B, page 32) attaching the sliding guide post nearest to the access door being repaired.
5. Lift up slightly the structural member (G) extremity and the access door upper plastic cover to disengage the door upper outer hinge (F) and spacer (E) from under the structural member.
6. Lift the door and disengage it from the lower outer hinge (J). Lay the access door on a workbench.
7. Using a Phillips screwdriver, remove the two screws (K) holding the two parts of both release knobs. Remove the release knobs.
8. Identify the defective component among the followings: release knobs (L), upper (F, M) or lower (J, N) hinge mechanism, hinge sleeve (O), locking bars (P) or the compression spring (Q). Replace the defective component.

NOTE

Apply grease on the hinge mechanism and the compression spring at reassembly.

9. Reinstall the access door on the siderail.
10. Check the door and the release knobs for proper operation before reinstalling the siderail upper plastic cover. Make sure the door locks when closed. Verify that the open/close indicators show green when the door is closed and locked, and yellow when it is opened.

RELEASE KNOB**Required Tools:**

Phillips screwdriver

Procedure:

1. Apply the stretcher brake. Raise the siderail needing repair.
2. Open the access door needing repair.
3. Using a Phillips screwdriver, remove the two screws (K) holding the two parts of the release knobs (L). Remove the defective release knob.
4. Install the new release knob.
5. Test the release knob for proper operation. Make sure the open/close indicators will show green when the door is closed and yellow when it is open.

UPPER/LOWER PLASTIC COVER

Required Tools:

5/32" Allen Key

Medium Strength Thread Locker

1/2" Wrench

Phillips Screwdriver

Procedure:

1. Proceed with step one through six of the "Hinge and Latch Component" replacement procedure, page 38.
2. **Upper Plastic Cover:** Using a Phillips screwdriver, remove the four screws (R) holding the upper plastic cover (S) to its lower counterpart.
Lower Plastic Cover: Using a Phillips screwdriver, remove the four screws (T) holding the lower plastic cover (U) to its upper counterpart.

NOTE

Remove the defective cover carefully to avoid damaging the lower or upper cover snap fit pins.

3. Install the new cover taking care that the snap fit pins match the posts of the upper or lower cover.
4. Reinstall the access door on the siderail.
5. Check the door and the release knobs for proper operation before reinstalling the siderail upper plastic cover. Make sure the open/close indicators will show green when the door is closed and yellow when it is opened.

ACCESS DOOR REMOVAL

NOTE

To completely remove an access door, proceed with step one through six of the "Hinge and Latch Mechanism Component Replacement " procedure, page 38.

ANNEX A: Installation Procedure for a Fixed Endrail

NOTE

Beds equipped with a fixed endrail will be packaged with the endrail down to prevent damage to the rail during transportation. The following procedure describes how to mount the endrail to its definitive position upon reception of the bed.

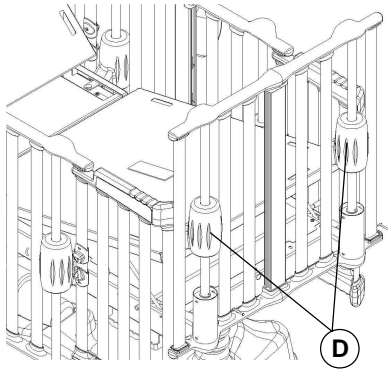

Figure A

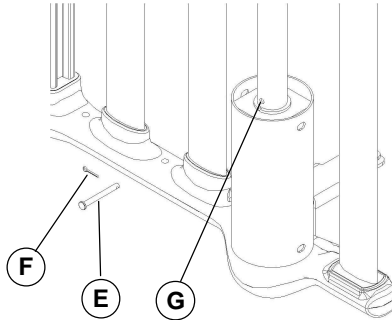

Figure B

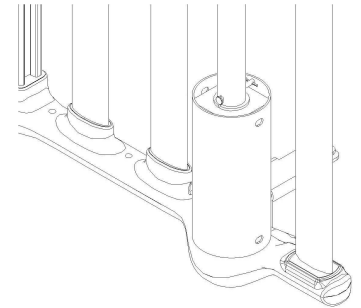

Figure C

Installation procedure:

1. Raise and maintain the endrail in high position (Fig. A).
2. Raise the barrel covers (D).
3. Insert the lock rods (E) in the holes provided (G)
4. Insert the cotter pins (F) to block the lock rods (Fig. C).
5. Remove the white powder from the barrels and reinstall the barrel covers (D).
6. Make sure the endrail is securely mounted.